

Review on Closed Loop Automated Irrigation System

Rekha B Venkatapur¹ and S Nikitha²

¹Professor, Department of Computer Science and Engineering,
K. S. Institute of Technology, Bangalore, Karnataka, India

²Assistant Professor, Department of Computer Science and Engineering,
Jyothy Institute of Technology, Bangalore, Karnataka, India
E-Mail: nikithasudheer@gmail.com

Abstract - India is mainly an agricultural country. Irrigation is a vital component of agricultural production. Irrigation is a process of applying controlled amount of water to plants at regular interval. There are various technological improvements in irrigation including automated irrigation. Compared to manual irrigation, automated irrigation system can save water and maximize productivity. Automated irrigation system can be either closed/feedback control system or open/non-feedback control system. Feedback control systems monitor's environmental parameters to control irrigation. Closed loop control system can be either plant/crop based system or soil based system. This paper reviews the various closed loop automatic irrigation system and proposes an automated irrigation system using thermography. The proposed system uses an IR thermal camera to capture IR image of plant canopy. Captured IR image is superimposed with digital image to identify water deficit area and corresponding valve is opened to start irrigation. The amount of water to be applied is controlled by soil moisture sensor deployed on agriculture field. When sensor value reaches the predefined threshold value corresponding valve is closed to stop irrigation. Efficient water management system is proposed by using plant or leaf canopy temperature to start irrigation.

Keywords: Plant canopy, IR image, sensors, wireless sensor network (WSN) etc.

I. INTRODUCTION

India is the largest freshwater user in the world. 86% of water is used for agriculture, 5% for industry and remaining 8% for domestic purpose. Water plays an important role in plant lifecycle. Irrigation system can be classified as either manual or automatic. Type of irrigation used in agriculture influences crop production. In manual irrigation farmer irrigate the land at regular interval. This method may sometimes lead to over or under irrigation. Manual irrigation takes lot of time and effort. In automated irrigation water is supplied only when it is required with minimal or no human intervention. Farmer work is made simpler by using automation in irrigation system. Sensor based automated irrigation system provides promising solution to farmers. Automated irrigation system can use some high tech solutions such as Time Based System, Volume Based System, open loop systems, closed loop systems, real time feedback system and computer based irrigation control systems. Fresh water consumption in agriculture can be reduced by using efficient water

management system for irrigation. Precision Irrigation applies the water efficiently, improves crop quality and saves money and water.

WSN is a wireless network of self monitored geographically distributed autonomous nodes. Nodes in a network use various sensors to monitor physical or environmental parameters such as temperature, pressure, sound, etc. Each node in the network consists of four main components. They are radio, processor, sensor and battery. Sensor nodes collect data and transmit it over wireless medium to a central system where data from all nodes are collected and processed. WSN are used in many applications such as health monitoring, agriculture, environmental monitoring, military applications, etc. WSN has a wide application in agriculture domain to monitor land and water resources. Various sensors such as moisture, temperature, humidity and etc. are used to monitor soil parameters which are used to control irrigation system. For sensing soil moisture level, the sensor is deployed spatially on agriculture field. Based on the received sensor value irrigation is scheduled.

Research in agriculture had showed that plant water status can be used to design efficient water management system. Leaf or canopy temperature is used to automate irrigation. Plant canopy temperature distribution is acquired via thermal imaging. Thermography has several advantages compared to commonly used methods for water status detection such as soil water content or crop evaporation by climatic parameters. It is a non-invasive, rapid and reliable method. Such a system can optimize irrigation water usage. The use of canopy temperature as an indicator of plant water status measured by infrared cameras is based on the principle that plant stomata closure takes place during water stress, which results in a decrease of energy dissipation and an increase of canopy temperature.

In soil based system selecting position that is representative of root zone is difficult. Plant takes around 70% of water from upper half of the root zone. Plant based system measure plant water stress directly but does not indicate the amount of water to be applied. Soil based system can be combined with plant based system such as plant canopy temperature measurement to design water efficient irrigation system.

II. LITERATURE SURVEY

Raspberry Pi using IR thermal camera in agriculture farm for smart irrigation system [1] proposes an automatic irrigation system for agriculture lands using raspberry pi and thermal camera. The proposed system captures thermal image of an agriculture land with the help of MLX90620 image sensor. The captured image is divided into 4 parts. Image processing algorithm is applied separately on each part to identify temperature difference. Based on the temperature value wetness level of the land is identified. High temperature denotes the dry land. The raspberry pi pocket computer identifies dry area and opens the corresponding valve to irrigate the dry area. Irrigation system is completely controlled using land temperature. Proposed system also includes water tank monitoring system using ultrasonic distance sensor.

Application of infrared thermography technology for irrigation scheduling of winter wheat [2] proposed an automatic irrigation system for winter wheat in China. The proposed system uses infrared thermography to capture thermal image of the wheat to obtain temperature of canopy (Tcanopy) and its background. Temperature of reference leaves are used to calculate two parameters Twet and Tdry. Crop water stress index (CWSI) is calculated using Twet, Tdry and Tcanopy. CWSI which is an indicator of plant water status is used to control irrigation scheduling. Different temperatures are displayed in different colors in modern infrared thermography using RGB color model. To get the accurate temperature, firstly, image noise is removed using image smoothing. Secondly, desired part of the image is highlighted using color image enhancement. Then temperature of reference leaves (Twet and Tdry) is used to remove the background such as weed and soil. After image processing CWSI value is calculated to control the irrigation schedule.

Online Farming Based On Embedded Systems and Wireless Sensor Networks [3] uses IP-cameras and wireless network to remotely monitor farm. There are 3 main modules in proposed system namely front end consisting of various sensors arranged in predefined format to monitor soil parameters and camera to capture live videos. All the transmissions from front end take place with the help of ZigBee. Video motion analysis technique is used to transmit video signal with less bandwidth. Management module performs the required action such as controlling irrigation by opening and closing valve by comparing received data with its database and uploads the received data into the network with the help of internet. Management module receives data using ZigBee and transfers received data to system using internet. User of the proposed system can control system remotely using internet via monitoring and control module. The farming website consists of home page, user page and user profile page through which the farmer can log-in and view live status of farm.

An Automatic Irrigation System using ZigBee in Wireless Sensor Network [4] Proposes automatic irrigation system using WSN to improve quantity and quality of crop production. Proposed system uses three main nodes namely node 1 and node 2 as sensing node and node 3 as receiver node. Node 1 and node 2 perform same operation but have different destination address. Address is set on receiver node. Receiver node plays an important role in automating irrigation system. ZigBee is used to transfer the sensed information from node 1 and 2 to receiver node. Receiver node displays the received information on LCD and PC and sends it to 18F458 microcontroller. Threshold value is selected based on crop type. Particular crop is monitored by comparing the threshold value with running value. Automatic operation starts when running value crosses the threshold value.

Automatic Control of Irrigation System in Paddy Using WSN [5] Proposed automatic irrigation system using moisture sensor and water level sensor to automate water flow to paddy field. Water flow is controlled by valve and GSM modem is used to send SMS to farmer regarding time taken to fill the paddy field with water. Moisture sensor sends the sensing information to microcontroller using ZigBee. Microcontroller compares the received value with stored threshold value. If received value is less than threshold value then microcontroller opens valve to direct water to farm. If not, solenoid valve remains closed. Water level sensor sends measured water level value to microcontroller using ZigBee. Microcontroller compares the received value with threshold value. If received water level value is lesser than threshold value then valve remains open and water flow continuously inside the farm. If received value crosses the threshold value microcontroller closes valve to stop irrigation.

Precision Agriculture Applications using Wireless Moisture Sensor Network [6] Proposes Green House Management System (GHMS) using WSN. GHMS uses three sensors namely moisture, humidity and temperature sensor. GHMS uses moisture sensor to monitor wetness of soil, humidity sensor to monitor wetness of air and temperature sensor to monitor heat of the air in the greenhouse. Based on the sensor value GHMS automatically decides to ON or OFF devices such as water pump for irrigation, fan for air circulation and mist for adding water in the air. Proposed system was tested on 1000 chili plants. Water pump is activated to start irrigation when received moisture sensor value is below threshold value (35 VWC).

Automatic Irrigation System Using Wireless Sensor Networks [7] Proposes automatic irrigation system using WSN. Each node in network consists of temperature and moisture sensor. Base station assigns unique address for each node to initialize network. When the base station requires temperature and moisture level of a particular area, it broadcasts the address of the sensor node which is deployed over there. All the nodes received this address but only the addressed node responded to this request by

sending back the present value of the moisture and the temperature of that region. Base station compares the received value with threshold value stored in database. If measured value is lesser than threshold value the controller performs necessary actions. The same procedure is used for all the nodes in the network.

IOT Based Automatic Drip Irrigation System [8] calculates the crop water requirement for the farm based on soil moisture, humidity sensor values. These values are used to decide and control the amount of water required to supply through valves and then to drippers. Smart drip irrigation system consists of numerous hardware devices communicating with each other: Base station communicating with actuator node to turn it ON/OFF. Actuator node has relay and electromechanical valve connected to microcontroller unit that is used for actuating the valves. The actuator/node is controlled by the microcontroller being placed at irrigation system. That in turn communicates with the base station through XBee module wirelessly. It consists of base station, actuator node and irrigation module. Base station has battery enabled single board computer that communicates with node/actuator device through XBee radio. The actuator node consists of microcontroller and a battery. This microcontroller is programmed to perform actuation of valves based on input from the base station. Base station has the database that stores the information regarding status of

all the valves and is also equipped with decision support system that calculates crop water requirement for the region to be irrigated. The decision for actuating the electromagnetic valves is based on when some area of the field is found to be in stress condition due to soil moisture, temperature, humidity, solar radiation or combination of them.

Smart Drip Irrigation System for Sustainable Agriculture [9] using GSM and ARM processor proposed fully automated drip irrigation system. The automated system is used to turn on valves ON and OFF as per the plants water requirement. Different sensors are used to monitor different parameters of soil such as moisture, PH, nitrogen and temperature. Depending upon the sensor output ARM9 processor will take necessary action. Based on the soil type and plant threshold value are selected. The moisture sensor and temperature sensor output helps to determine whether or not to irrigate the land. Depending upon measured PH value suggestion is given to farmer to add various chemicals in order to achieve the desired PH of the soil. The proposed system also detects the nitrogen content in the soil. According to the available nitrogen content in the soil suggestion are given to the farmer to add fertilizer containing nitrogen for healthy plant growth. GSM is used for remotely monitoring and controlling the devices via mobile phone by sending SMS.

TABLE I SUMMARY OF LITERATURE SURVEY

S. No.	Paper Details	Approach	Methodology	Advantage	Disadvantage
1	Title: Raspberry Pi using IR thermal camera in agriculture farm for smart irrigation system Author : S.Pushpavel et al Year: 2015	Thermal Sensing	Proposed system captures the thermal image of agriculture land. Captured image is divided in to four parts. Image processing algorithm is applied separately to identify temperature difference. Based on the temperature value dry area is identified and irrigated.	1. It is a direct measure of plant water stress.	1. Thermal camera installation height, angle and view should be carefully identified. 2. Does not give any indication of how much water to be applied. 3. Available thermal cameras are mainly used for non agriculture use.
2	Title: Application of infrared thermography technology for irrigation scheduling of winter wheat Author : Zhenfang Hu et al Year: 2011	Thermal Sensing	Proposed system uses thermography to capture thermal image of wheat. Captured image is used to calculate Tcanopy. Using Tcanopy, Twet and Tdry CWSI is calculated. CWSI is used to schedule irrigation.	1. It is a direct measure of plant water stress. 2. Using canopy temperature water efficient irrigation management system can be designed	1. Canopy temperature is affected by environmental conditions. 2. Thermal camera installation height, angle and view should be carefully identified. 3. Does not give any indication of how much water to be applied. 4. Available thermal cameras are mainly used for non agriculture use.
3	Title: Online Farming Based On Embedded Systems and	Soil water measurement	Proposed system uses IP cameras and wireless network to remotely monitor	1. Easy to apply in practice. 2. Provides remote	1. Selecting the position that is representative of root zone is difficult. 2. Not accurate as direct

	Wireless Sensor Networks Author: K.Sathish kannan et al Year: 2013		farm. System consists of three modules. Front end uses various sensors to monitor soil parameters. Management module control irrigation and monitoring module monitors and controls the system using internet.	monitoring and control.	measure.
4	Title: An Automatic Irrigation System using ZigBee in Wireless Sensor Network Author: Pravina B et al Year: 2015	Soil water measurement	Proposed system uses various sensors to monitor soil parameters. System consists of three nodes in which node1 and 2 are sensing nodes and node 3 is receiving node. Sensing information is transmitted from receiving node to microcontroller and PC. Received value is compared with threshold value of crop to automate irrigation.	1. Easy to apply in practice. 2. Less Expensive.	1. Selecting the position that is representative of root zone is difficult. 2. Not accurate as direct measure.
5	Title: Automatic Control of Irrigation System in Paddy Using WSN Author: A. Sathya et al Year: 2016	Soil water measurement	The proposed system uses moisture sensor and water level sensor to automate irrigation. Moisture sensor value is compared with threshold value to start irrigation. Water level sensor value is used to stop irrigation. Time taken for irrigation is sent as an SMS to farmers mobile phone	1. Easy to apply in practice. 2. Less Expensive. 3. Provides remote monitoring using mobile phone	1. Selecting the position that is representative of root zone is difficult. 2. Not accurate as direct measure.
6	Title: Precision Agriculture Applications using Wireless Moisture Sensor Network Author: Ibrahim Mat et al Year: 2015	Soil water measurement	Proposed Green House Management System (GHMS) using wireless technology. Based on the sensor values GHMS automates the irrigation. Proposed system was tested on 100 chili plants.	1. Easy to apply in practice. 2. Less Expensive.	1. Not accurate as direct measure.
7	Title: Automatic Irrigation System Using Wireless Sensor Networks Author: Gaurav Soni et al Year: 2015	Soil water measurement	Proposed automatic irrigation system using WSN. Moisture and temperature sensor values are used to control irrigation.	1. Easy to apply in practice. 2. Less Expensive.	1. Selecting the position that is representative of root zone is difficult. 2. Not accurate as direct measure.
8	Title: IOT Based Automatic Drip Irrigation System Author: Ameya Bhale et al	Soil water measurement	Proposed citrus crop water Management using moisture, temperature and humidity sensor. Sensor values are used to decide and control	1. Easy to apply in practice. 2. Less Expensive.	1. Not accurate as direct measure.

	Year: 2014		the amount of water required to supply through valves and then to drippers.		
9	Title: Smart Drip Irrigation System for Sustainable Agriculture Author: G kaviyanand et al Year: 2016	Soil water measurement	GSM and ARM processor are used to design fully automated drip irrigation system. Proposed system monitors soil parameters using different sensors. Based on received sensor value ARM9 processor will take necessary action such as opening and closing the valve. Depending upon measured PH value suggestion is given to farmer through phone to add various chemicals.	1. Easy to apply in practice. 2. Less Expensive. 3. Provides remote monitoring using mobile phone	1. Selecting the position that is representative of root zone is difficult. 2. Not accurate as direct measure.

III. SYSTEM DESIGN

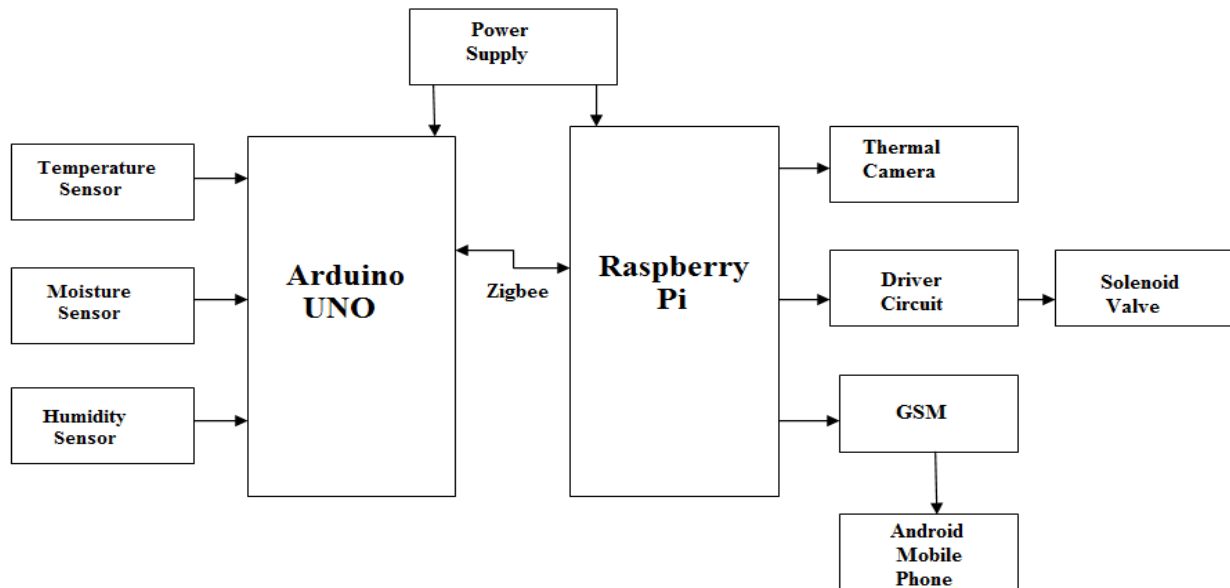

Fig.1 Block Diagram of Automated Irrigation System Using Infrared Thermography

Automated irrigation system can be classified as either open loop control system or closed loop control system. In open loop control system decision on amount of water to be applied and the timing of irrigation is made by operator. Open loop control system is based on timer or amount of water applied. In closed loop system operators develop a general control strategy. The control system makes decisions on when to apply water and how much water to apply based on general control strategy. Closed loop system uses feedback from sensors or real time feedback from plant. Closed loop systems can be either plant based system

or soil based system. Each system has its own advantages and disadvantages. Plant based system measures the plant stress response directly. Which can be used to schedule irrigation but it does not provide any information regarding amount of water to be applied. In soil based system various sensors are used to monitor soil parameters but selecting position that is representative of the root zone is difficult. Soil based system is not accurate as direct measure but it can indicate the amount of water to be applied. Proposed system uses plant based system to schedule irrigation and soil based system to decide amount of water to be applied.

Block diagram of a proposed system is shown in figure. The proposed system uses IR thermal camera to capture thermal image of plant leaves. When plant goes in to water stress their stomata begin to close which in turn increases canopy temperature. To get the accurate temperature image processing algorithm is applied to thermal image. Proposed algorithm identifies the temperature difference by comparing optical image with IR image. Based on the canopy temperature difference Raspberry Pi identifies the dry area and opens the corresponding valve to start irrigation. Pi closes the valve to stop irrigation when moisture sensor value reaches the predefined threshold value.

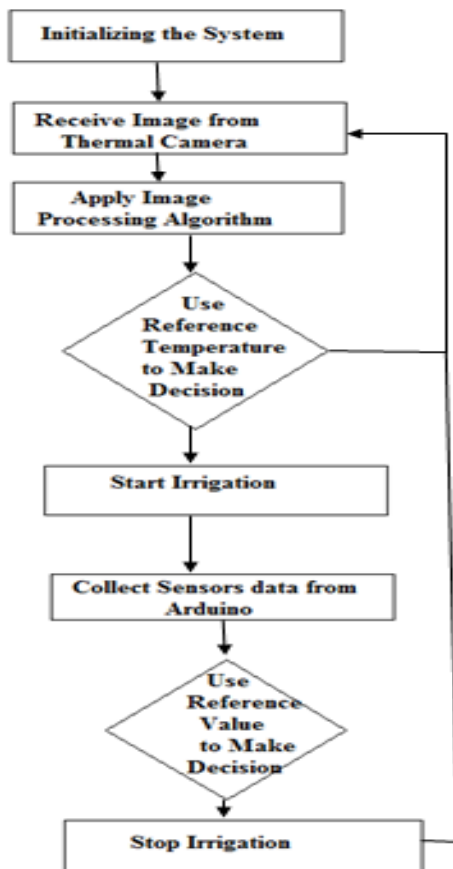

Fig.2 System Flow Chart

IV. CONCLUSION

Both soil based and plant based irrigation system has its own advantage and disadvantage. The proposed system uses both soil parameter such as moisture status and plant water stresses such as canopy temperature to design efficient water management system. Proposed automated irrigation system uses IR thermal camera to capture thermal image of plant leaves and wireless moisture sensor network to monitor soil moisture status. Canopy temperature is used to schedule the irrigation. Sensor value is used to identify amount of water to be applied. Based on the canopy temperature difference, Raspberry Pi identifies the dry area and opens the corresponding valve to start irrigation. When moisture sensor value reaches the predefined threshold pi closes the corresponding valve to stop irrigation. Proposed system can be improved by designing it to a particular plant/crop.

REFERENCES

- [1] S.Pushpavel and P.Saravanan Raspberry Pi Using IR Thermal Camera in Agriculture Farm for Smart Irrigation System International Research Journal of Engineering and Technology (IRJET) e-ISSN: 2395 -0056 Vol. 2, No.8, Nov-2015.
- [2] Zhenfang Hu, Wenyong Du and Xiongui He "Application of infrared thermography technology for irrigation scheduling of winter wheat".
- [3] K.Sathish kannan and G.Thilagavathi "Online Farming Based on Embedded Systems and Wireless Sensor Networks", 2013 International Conference on Computation of Power, Energy, Information and Communication (TCCPEIC)
- [4] Pravina B. Chikankar, Deepak Mehetre and Soumitra Das, "An Automatic Irrigation System using ZigBee in Wireless Sensor Network," International Conference on Pervasive Computing (ICPC).
- [5] A. Sathya, B. Arthi S. Giridharan, M. Karvendan and J. Kishore , "Automatic Control of Irrigation System in Paddy Using WSN," 2016. IEEE International Conference on Technological Innovations in ICT For Agriculture and Rural Development (TIAR 2016).
- [6] Ibrahim Mat, Mohamed Rawidean Mohd Kassim, and Ahmad Nizar Harun, "Precision Agriculture Applications using Wireless Moisture Sensor Network:" IEEE 12th Malaysia International Conference on Communications (MICC), Kuching, Malaysia, pp. 23, 25 Nov 2015.
- [7] Gaurav Soni and Navdeep Singh, "Automatic Irrigation System Using Wireless Sensor Networks International Journal of New Technology and Research" (IJNTR) ISSN: 2454-4116, Vol. 1, No..2, June 2015.
- [8] Ameya Bhale, Suryakant Sawant, Surya Durbha and J.Adinarayana, Iot Based Automatic Drip Irrigation System Geomatrix 14.
- [9] G kaviyanand, V M Nivas, R kiruthika and S Lalitha, Smart drip irrigation system for sustainable agriculture.